

MOTOR SPECIFICATION SHEET

MODEL : SCL-QR 10HP 4P

USED FOR : STANDARD

DESCRIPTION	DETAIL			
PHASE	1			
TYPE	CAPACITOR START AND RUN			
MODEL NAME	SCL-QR			
RATED OUTPUT, HP (kW)	10 (7.5)			
POLE	4			
CODE	MEATH CODE : 1M001D-400750QRES0			
OUTLINE DRAWING NO.	ONM24O065-*			
RATED VOLTAGE (V)	220	230	220	
RATED FREQUENCY (Hz)	50	50	60	
RATED CURRENT (A)	43.5	41.0	41.0	
RATED SPEED (min ⁻¹)	1440	1450	1730	
RATED EFFICIENCY (%)	86.3	86.3	87.5	
THERMAL CLASS	155(F)			
RATING	S1 (CONTINUOUS)			
ENCLOSURE CONSTRUCTION	DRIP-PROOF			
DEGREES OF PROTECTION	IP22			
METHOD OF COOLING	IC01			
FRAME NO.	132ML			
WEIGHT (kg)	66.4			
STANDARD	JEC-2137-2000			
EFFICIENCY RULE	IEC 60034-30-1			
INSTALLATION	FOOT MOUNTED			
ROTATION	CCW (VIEWED FROM SHAFT END)			
BEARING	LOAD SIDE : 6308ZZ			
	OPPOSITE SIDE : 6207ZZ			
BEARING GREASE	UREA GREASE			
VIBRATION	V20			
CIRCUMSTANCE CONDITION	AMBIENT TEMPERATURE : -20 ~ +40°C			
	AMBIENT HUMIDITY : 85%RH OR LESS			
	ABOVE SEA LEVEL : 1000m OR LESS			
	ENVIRONMENT : NO BURSTING/EROSIVE GAS OR VAPOR			
COLOR	MUNSELL N1.5 (BLACK)			
TERMINAL BOX	NO. OF LEAD WIRES : 4			
	SOURCE CONNECTION : LEAD WIRES			
INSULATION RESISTANCE	BY DC 500V MEGGER - ≥100MΩ			
DIELECTRIC TEST	AC 50Hz 1500V - 1min. (Based on rated voltage 220V)			
SHAFT SWING	≤0.03mm			
MATERIAL	FRAME : STEEL PLATE			
	BRACKET : ALUMINIUM			
	SHAFT : CARBON STEEL			
	STATOR CORE : ELECTRICAL STEEL			
	WIRE : ENAMELLED COPPER MAGNET WIRE			
	INSULATOR : POLYESTER FILM SATURATED WITH RESIN			
	VARNISH : EPOXY DENATURALIZATION POLYESTER			
	ROTOR CORE : ELECTRICAL STEEL			
	CONDUCTOR : ALUMINIUM			
	TERMINAL BOX : STEEL PLATE			
PAINTING : POLYURETHANE RESIN				
PRODUCTION COUNTRY	THAILAND			

Specifications subject to change without notice.

SPECIFICATION SHEET NO.

SS-M-2309-A

MODEL SCL-QR SINGLE PHASE INDUCTION MOTOR OUTLINE DRAWING

CAPACITOR START CAPACITOR RUN TYPE
(DEGREE OF PROTECTION IP22)

CUSTOMER _____
 USER _____
 FOR _____
 CUSTOMER'S ORDER NO. _____
 QUANTITY _____
 MFG. ORDER NO. _____

STARTING CAPACITOR	455 uF 300 V
RUNNING CAPACITOR	75 uF 520 V

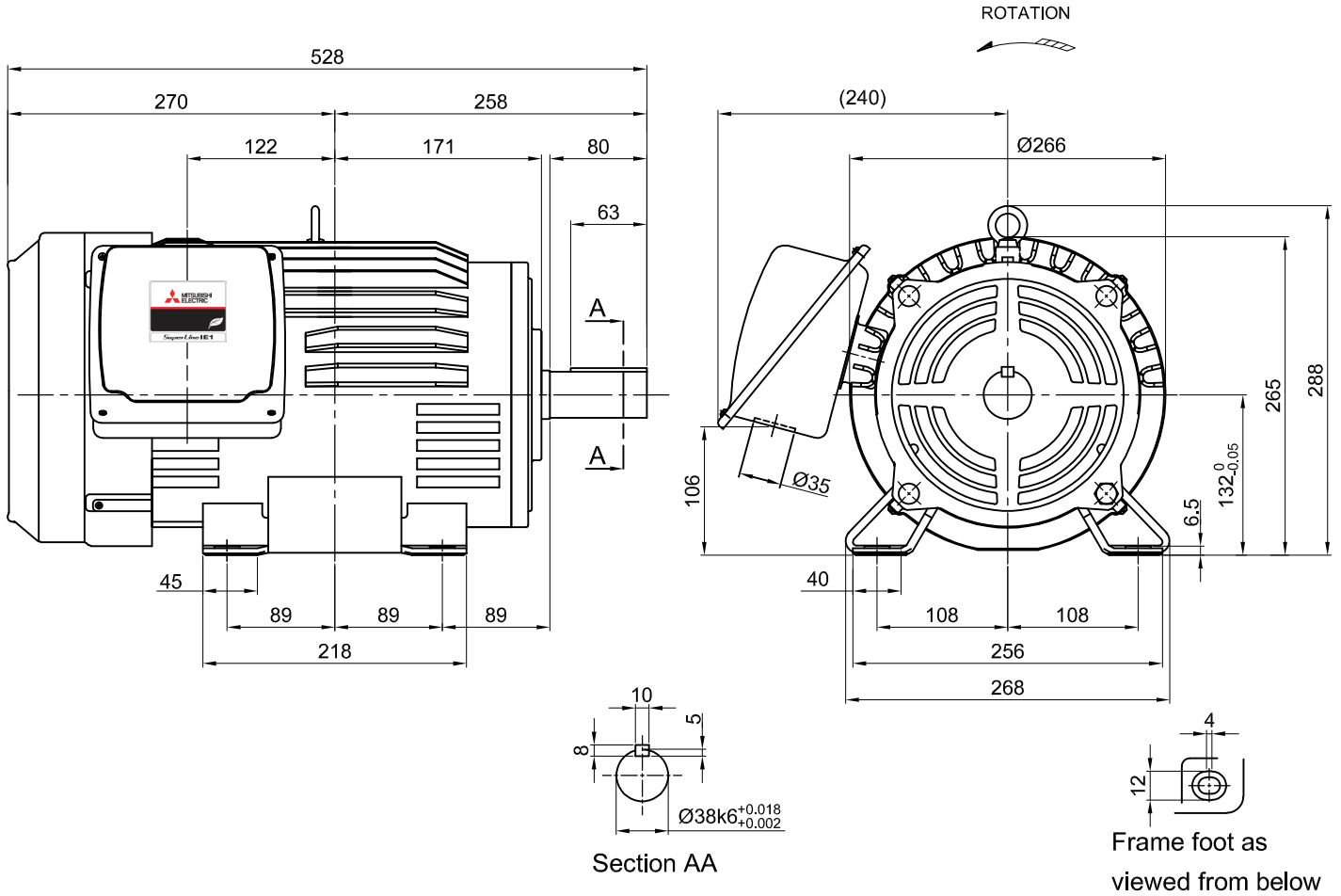

FRAME SIZE	RATING	TH CLASS	AMB. TEMP.	BEARINGS		COLOR	DIRECTION OF ROTATION	NO. OF LEAD WIRE
				LOAD SIDE	OPP. SIDE			
132ML	S1	F	40°C	6308ZZ	6207ZZ	BLACK (MUNSELL N1.5)	CCW	4

OUTPUT		POLE	HERTZ	VOLTS	AMP.	RPM	IE CODE - RATED EFF.	REMARKS
HP	KW							
10	7.5	4	50	220/230	43.5/41.0	1440/1450	IE1 - 86.3% / IE1 - 86.3%	
			60	220	41.0	1730	IE1 - 87.5%	

MITSUBISHI ELECTRIC AUTOMATION (THAILAND) CO.,LTD.

	OUTLINE DRAWING NO.	REV.
	ONM240065	*
DIMENSION IN mm.		
SCALE : NTS		